

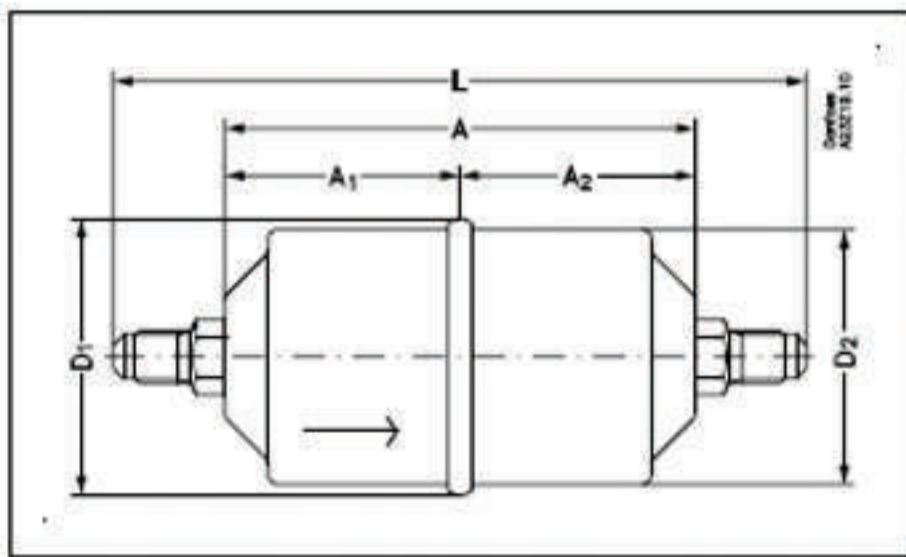

Data Sheet

Hermetic filter drier Type **DML** and **DCL**

For uniflow liquid line



All ELIMINATOR® driers have a solid core with binding material held to an absolute minimum.

There are two types of ELIMINATOR® cores. Type DML driers have a core composition of 100% Molecular Sieve, while type DCL contain 80% Molecular Sieve with 20% activated alumina.

ELIMINATOR® type DML driers are designed for applications requiring the highest moisture capacity.

ELIMINATOR® type DCL driers are designed for applications requiring high moisture capacity and acid adsorption capacity.

Available with solder (cu-plated steel connectors) and flare connections.

For other connections please contact your Danfoss Sales Representative.

Type	A [mm]	A1 [mm]	A2 [mm]	L [mm]	D1 [mm]	D2 [mm]	Net weight [Kg]
DCL / DML 082	101	50.5	50.5	145	58	54	0.31
DCL / DML 083	101	50.5	50.5	158	58	54	0.35
DCL / DML 084	101	50.5	50.5	166	58	54	0.37
DCL / DML 085	101	50.5	50.5	175	58	54	0.4
DCL / DML 162	110	55	55	154	80	76	0.65
DCL / DML 163	110	55	55	167	80	76	0.67
DCL / DML 164	110	55	55	175	80	76	0.74
DCL / DML 165	110	55	55	184	80	76	0.74
DCL / DML 166	110	55	55	182	80	76	0.84